



# BI-DIRECTIONAL INVERTER

## USER MANUAL

### Kinergier Mobile Series





5min



**WARNING: HIGH VOLTAGE INSIDE**

**CAUTION: THE DC FUSE MUST HAVE BEEN TURNED OFF BEFORE SERVICING**

**MADE IN CHINA**

## IMPORTANT SAFETY INSTRUCTIONS

### SAVE THESE INSTRUCTIONS

**WARNING:** NEUTRAL FLOATING. Risk of electric shock. Use only (manufacturer's name), type (catalog number) ground-fault circuit-interrupter [receptacle(s) or circuit breaker(s)]. Other types may fail to operate properly when connected to this unit.

**WARNING:** This unit employs components that tend to produce arcs or sparks – To prevent fire or explosion, do not install in compartments containing batteries or flammable materials. Provided with integral protection against overloads.

**CAUTION:** To prevent fire, do not cover or obstruct ventilation openings. Do not mount in zero-clearance compartment. Overheating may result.

## IMPORTANTES INSTRUCTIONS DE SÉCURITÉ

### CONSERVEZ CES INSTRUCTIONS

**AVERTISSEMENT :** NEUTRE FLOTTANT. Risque d'électrocution. N'utilisez qu'un disjoncteur de fuite à la terre [prise(s) ou disjoncteur(s)] qualifié et conforme à la liste. Sinon, il risque de ne pas fonctionner correctement lorsqu'il est connecté à cet appareil.

**AVERTISSEMENT :** Cet appareil utilise des composants qui ont tendance à produire des arcs ou des étincelles - Pour éviter tout feu ou explosion, ne l'installez pas dans des compartiments contenant des batteries ou des matériaux inflammables. Fourni avec une protection intégrale contre les surcharges.

**ATTENTION :** Pour éviter tout feu, ne pas couvrir ou obstruer les ouvertures de ventilation. Ne pas monter dans un compartiment à dégagement nul. Une surchauffe pourrait en résulter.

## Disclaimer

Unless specially agreed in writing, TBB Power Co.,Ltd

- Take no warranty as to the accuracy, sufficiency of suitability of any technical or other information provided in this manual or other documentation.
- Assumes no responsibility or liability for loss or damage, or expense whether direct, indirect, consequential or incidental which might arise out of the use of such information.
- TBB offer standard warranty with its products, taking no responsibility for direct or indirect loss due to equipment failure.

## About this Manual

This manual describes our product features and provides procedure of installations. This manual is for anyone intending to install our equipment.

## General Instruction

Thanks for choosing our products and this manual were suitable for Kinergier Mobile bi-directional inverter. This chapter contains important safety and operation instructions. Read and keep this User Guide well for later reference.

The Kinergier Mobile bi-directional inverter needs to be installed by professionals and please pay attention to the following points prior to installation:

Please check the input voltage or voltage of battery is same to the nominal input voltage of this inverter.

- Please connect positive terminal “+” of battery to “+” input of the inverter.
- Please connect negative terminal “-” of battery to “-” input of the inverter.
- Please use the shortest cable to connect and ensure the secure connection.
- While connecting, please secure the connection and avoid short-circuiting the positive and negative poles of the battery, which will cause damage of battery.
- Inverter will have high voltage inside. Only authorized electrician can open the case.
- The inverter WAS NOT designed to use in any life retaining equipment.

# Contents

1. General Safety Instruction .....	1
1.1 Safety instruction .....	1
1.2 General precaution .....	1
1.3 Precaution regarding battery operation .....	1
2. Instruction .....	2
2.1 Brief Instruction.....	2
2.1.1 General Description .....	2
2.1.2 Naming Rules .....	2
2.2 Structure .....	3
2.2.1 Front.....	3
2.2.2 Control panel .....	3
2.2.3 Remote control and monitor MCK.....	4
2.2.4 Connection compartment.....	5
2.2.5 Dimension.....	6
2.3 Function.....	6
2.3.1 Power control and Power assist.....	6
2.3.2 Powerful and Reliable Inverter .....	6
2.3.3 Professional Battery Charger .....	7
2.3.4 Lithium Battery Compatible.....	8
2.3.5 Transfer .....	8
2.3.6 Protection .....	9
2.3.7 Communication.....	9
3. Installation and Wiring.....	10
4. Operation .....	11
4.1 Check before Operation.....	11
4.2 Power ON Test.....	11
4.3 Power OFF .....	11
5. Configuration .....	12
5.1 Default Setting .....	12
5.2 Configuration .....	12
5.2.1 TBB Interface.....	12
5.2.2 TBB Link.....	13
6. Specification .....	14

# 1. General Safety Instruction

## 1.1 Safety instruction

As dangerous voltages and high temperature exist within the Kinergier Mobile bi-directional inverter, only qualified and authorized maintenance personnel are permitted to open and repair it. Please make sure Kinergier Mobile bi-directional inverter is turned off before opening and repairing it.

This manual contains information concerning the installation and operation of the Kinergier Mobile bi-directional inverter. All relevant parts of the manual should be read prior to commencing the installation. Please follow the local stipulation meantime.

Any operation against safety requirement or against design, manufacture, safety standard is out of the manufacturer warranty.

## 1.2 General precaution

- DO NOT expose to dust, rain, snow or liquids of any type, it is designed for indoor use. DO NOT block off ventilation, otherwise the Kinergier Mobile bi-directional inverter would be overheating.
- To avoid fire and electric shock, make sure all cables selected with right gauge and being connected well. Smaller diameter and broken cable are not allowed to use.
- Please do not put any inflammable goods near to inverter.
- NEVER place unit directly above batteries; gases from a battery will corrode and damage Kinergier Mobile bi-directional inverter.
- DO NOT place battery over Kinergier Mobile bi-directional inverter.

## 1.3 Precaution regarding battery operation

- Use plenty of fresh water to clean in case battery acid contacts skin, clothing, or eyes and consult with doctor as soon as possible.
- The battery may generate flammable gas during charging. NEVER smoke or allow a spark or flame in vicinity of battery.
- DO NOT put the metal tool on the battery, spark and short circuit might lead to explosion.
- REMOVE all personal metal items such as rings, bracelets, necklaces, and watches while working with batteries. Batteries can cause short-circuit current high enough to make metal melt, and could cause severe burns.

## 2. Instruction

### 2.1 Brief Instruction

#### 2.1.1 General Description

Kinergier Mobile is the new generation bi-directional inverter designed for various on-board power application such as for RV, Utility Vehicle, Marine etc.

Kinergier Mobile delivers high reliability, performance and industry leading efficiency for mission critical application. Its distinguishing surge capability makes it capable to power most demanding appliances, such as air conditioner, water pump, washing machine, freezer, compressor, power tool etc.

With the function of power assist & power control, it can be used to work with a limited AC source such as generator or limited grid. Kinergier Mobile can automatically adjust its charging current avoiding grid or generator to be overloaded. In case of temporary peak power appear, it can work as the supplement source to generator or grid.

#### 2.1.2 Naming Rules

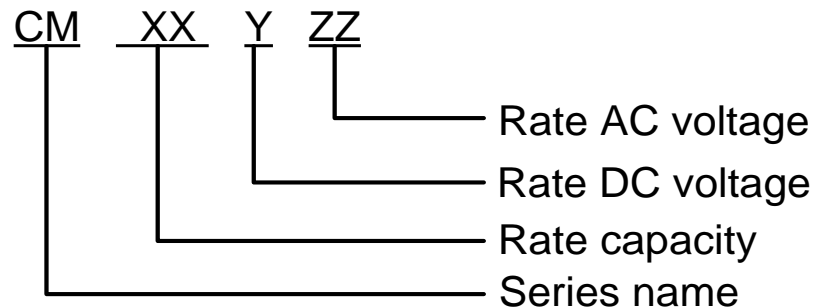

Figure	Explanation	
CM	series name	
2.0	Represent rated capacity	1600W(nom)
3.0		2400W(nom)
L	Represent rated DC voltage	12VDC
-LV	Represent rated AC voltage	120VAC

Naming example: CM3.0L-LV

Kinergier Mobile bi-directional inverter

Rated capacity: 2400W(nom)

Rated DC voltage: 12V

Rated AC voltage: 120V

## 2.2 Structure

### 2.2.1 Front



Figure 2-1 Bi-directional inverter structure in front view

### 2.2.2 Control panel

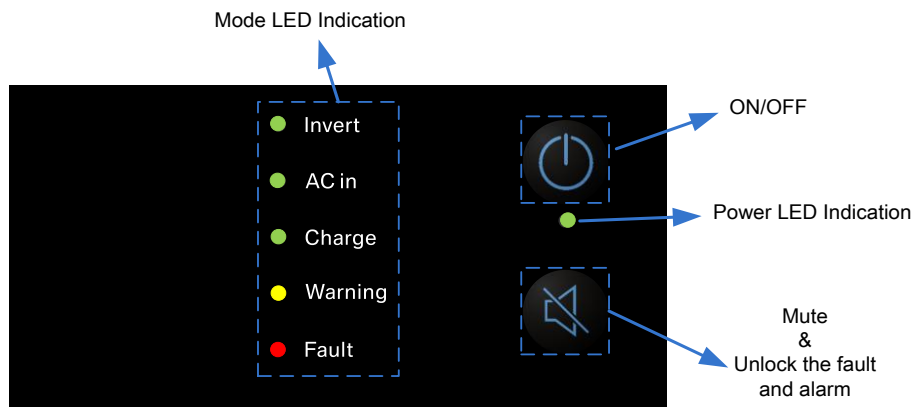

Figure 2-2 Bi-directional inverter Control buttons



Table 2-1 LED directive function

LED	Function
<b>Invert</b>	➤ It will illuminate when CM is inverting.
<b>AC In</b>	➤ It will flash when CM detect any input, mains or generator.
<b>Charge</b>	➤ It will flash when CM is in float charging. ➤ It will illuminate when CM is in bulk or absorption charging.
<b>Warning</b>	➤ It will flash when CM have warning.
<b>Fault</b>	➤ It will flash when CM have error.

**2.2.3 Remote control and monitor MCK**

Apart from above control panel, the user is also allowed to monitor, control and configure CM by a remote controller MCK. The MCK could be installed at a location with convenient access to user to monitor and operate CM.



Figure 2-3 Remote control and monitor MCK

More details of MCK about operation, installation and connection, please refers to the dedicated user manual which is attached in the box of MCK.

**2.2.4 Connection compartment**

Figure 2-4 Signal terminal

Table 2-2 Signal terminal introduction

No.	Silk-screen	Definition
①	Bat Sample	Battery temperature and voltage sample.
②	Remote	A dry contact input for remote on/off.
③	Com MON	RS485 port for external monitor such as MCK, SNMP etc.
④	Com Sync	Communication with TBB's M or P series lithium battery, which is able to synchronize lithium battery's charging and discharging strategy
⑤	Relay1 (NO,C,NC)	Dry contact output control 1(NO,C,NC)
⑥	Relay2 (NO,C,NC)	Dry contact output control 2(NO,C,NC)
⑦	S+	Slave charger for starter battery

## 2.2.5 Dimension

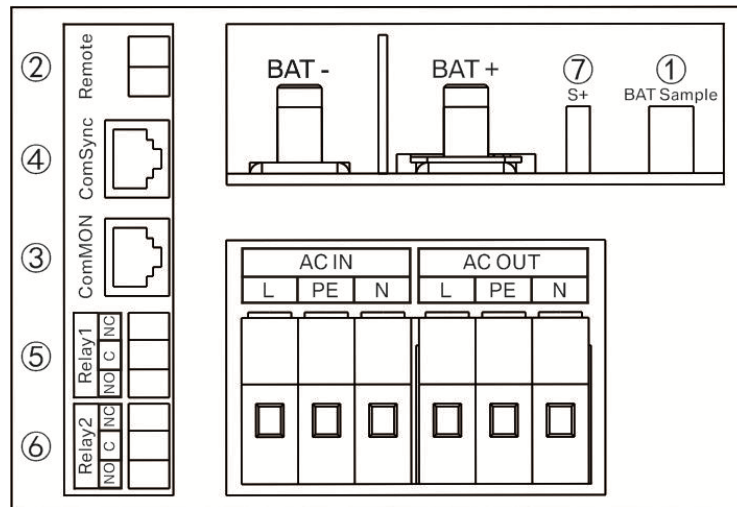
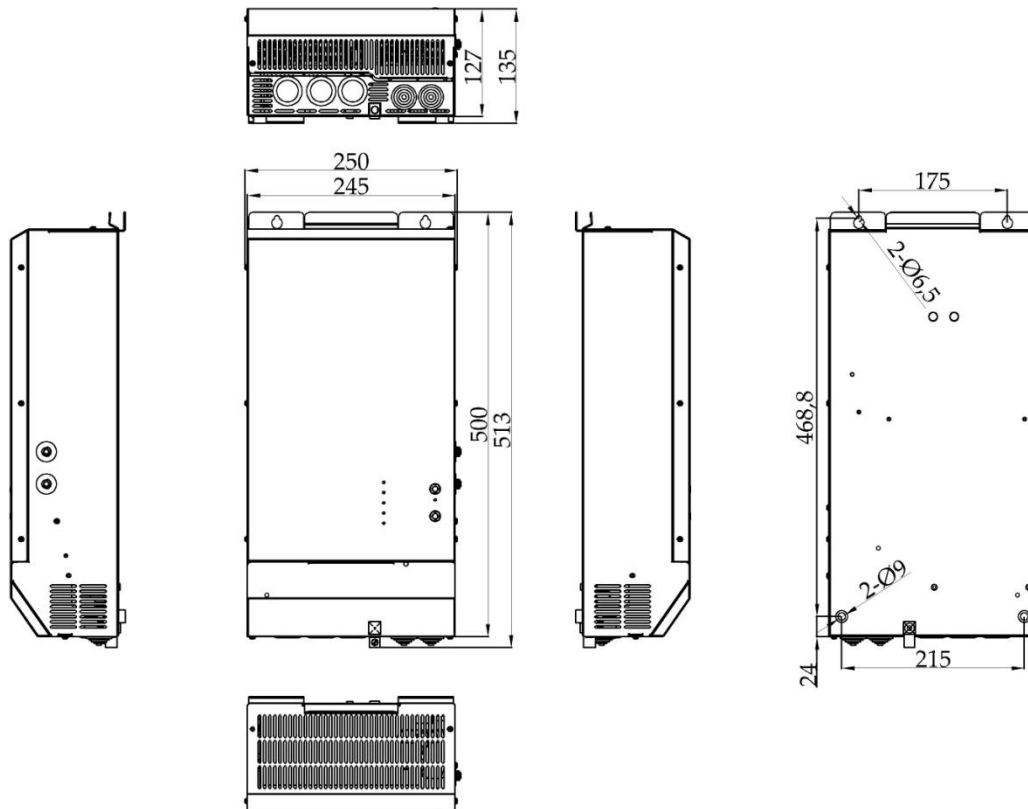

Figure 2-5 Dimension of Bi-directional inverter

## 2.3 Function

### 2.3.1 Power control and Power assist

Kinergier Mobile offers a unique feature of power control & power assist, which is very useful upon you have a limited grid supply or working with generator. Kinergier Mobile will take control of energy flow automatically, using extra power to charge the battery or inverting as the supplement to the grid or generator. With this feature, you can avoid tripping of shore power MCB or reduce generator capacity by up to 50%.

### 2.3.2 Powerful and Reliable Inverter

#### High performance pure sine wave

Kinergier Mobile is a pure sine wave inverter generating a near perfect sinusoidal AC wave power output that is very similar or even better to what you can get from your utility grid. Pure sine wave can guarantee the correct function of sensitive equipment (computer, laser printer, TV etc.). Also, your home appliances will work smoother, cooler and more efficient, such as fridge, microwave and power tools.

#### High surge power capability

Provided with outstanding surge power capability and low frequency transformer, Kinergier Mobile is suitable for heavy inductive load like fridge, coffee maker, microwave, power tools, air conditioner etc.

**Battery low voltage protect**

Kinergier Mobile provides configurable battery low voltage protection.

**2.3.3 Professional Battery Charger for lead acid battery**

**Multi stage sophisticated charging algorithm for lead acid battery**

Fitted with multistage charging algorithm (bulk-absorption-float-recycle), the built-in charger of Kinergier Mobile is designed to charge battery quickly and fully. Microprocessor controlled charging algorithm with variable absorption charging timer could guarantee the optimal charging for batteries of different discharged state.

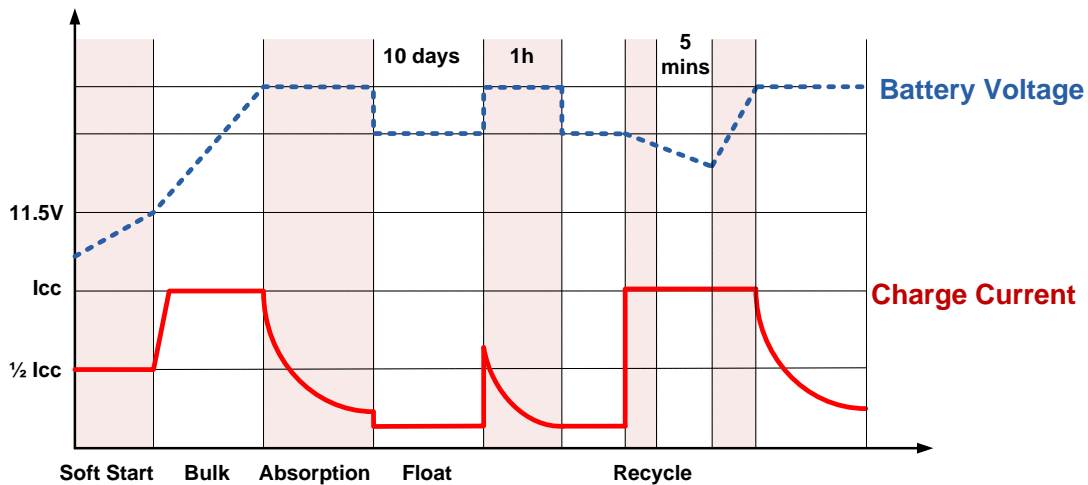

Figure 2-6 Multi stage sophisticated charging algorithm for lead acid battery

Float charging and recycle charging program guarantee your battery getting proper maintenance in case of long time connected and less aging in case of long time connected with no use.

**Battery Sample Cable (Temperature and voltage)**

Battery temperature is a key factor in correct charging for lead acid battery, the charging formula must be adjusted (automatically in real time) according to the actual battery temperature to ensure that battery is fully charged but not overcharged or undercharged. All charging voltages recommended by battery manufacturer are in fact ONLY applied at 20°C-25°C.

The Bat sample cable (battery temperature and voltage sensor) supplied with Kinergier Mobile measures the temperature of battery and automatically adjusts at real time to properly charge your batteries at compensation rate of  $-4\text{mV}/^\circ\text{C}/\text{cell}$ . In case of Bat sample cable is not present, Kinergier Mobile will use 25°C as default setting. This feature is especially recommended for sealed batteries and/or when important fluctuations of battery temperature are expected.

**Multi battery chemical available**

Kinergier Mobile offers premium charging algorithm for commonly encountered lead acid battery chemicals include AGM, GEL, Flooded, lead-carbon and Lithium battery, of which you can set through LCD interface and TBB Link software.

### 2.3.4 Lithium Battery Compatible

Kinergier Mobile support universal LFP charging profile and offered pre-defined LFP charging profile for TBB M and P series lithium battery.

#### Built in BMS pre-defined LFP charging and communication.

According to cell temperature and real time SOC, BMS will send command to battery charger asking for optimum charging voltage and current. This synchronization will prevent overheating or overcharging especially at the end of charging, to ensure the lithium battery reaches its target cycle life

In the meantime, instead of using voltage as protection, SOC value is used with more accuracy thus to avoid permanently dead of lithium battery due to left discharged for long time.

### 2.3.5 Transfer

#### Uninterrupted AC power

In case of voltage/frequency/waveform of AC input match the minimum quality, the voltage will be switched directly to AC output. Kinergier Mobile bi-directional inverter will work as a battery charger and load will be powered by AC input. You will have at the output the same voltage as AC input.

In case of AC input failure or exceeding the maximum AC input current set by the user, Kinergier Mobile bi-directional inverter will initiate a quick switching to inverter, of which will guarantee an undisturbed power. Upon AC input resume or match the quality, it will switch back again. Due to its ultra quick transfer design, as quick as 0ms, Kinergier Mobile bi-directional inverter could be used as an UPS.

#### Ground Relay

The neutral output of Kinergier Mobile bi-directional inverter is automatically connected to earth upon no external AC sources is available. Once external AC sources present, the ground relay will open. You can disable this feature through TBB Link.

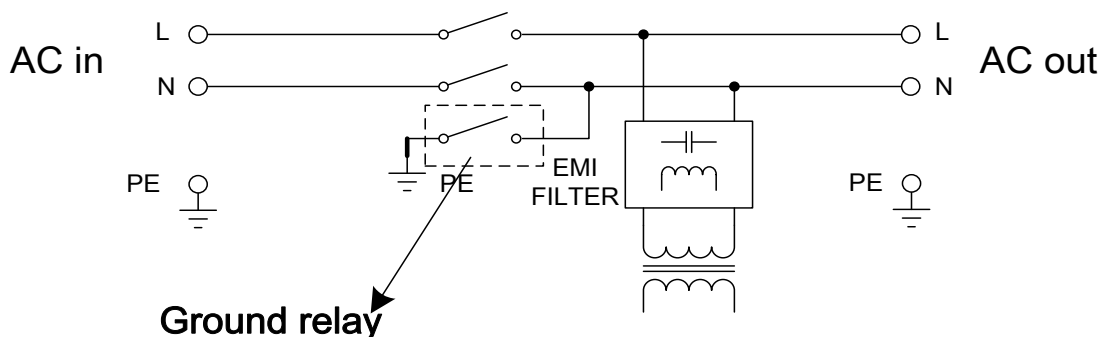

Figure 2-7 Ground Relay Schematic

### 2.3.6 Protection

The Kinergier Mobile bi-directional inverter is equipped with a series of complete hardware and software protection functions to ensure its stable and reliable operation.

#### **Overload protection**

When overload protection is trigger on, it will restart automatically after 60s. And after three consecutive overload shutdown protections, the equipment will not restart automatically. At this time, the user needs to manually restart.

#### **Over temperature protection**

When the internal temperature is too high, Kinergier Mobile will enter the over-temperature protection. After the internal temperature returns to normal, it can automatically resume normal operation.

#### **Short circuit protection**

The equipment will automatically shut down when the AC output is shorted and needs to be manually activated.

#### **Battery over temperature protection**

During the charging, the equipment will continuously monitor the battery temperature. When the battery temperature is too high, the equipment will automatically reduce the charging current. When the battery is severely heated, the charger will automatically turn off to protect the battery.

#### **Battery low voltage protection**

To prevent the permanent damage caused by the over discharge of battery, the equipment will automatically cut off the output according to the low voltage protection point set by the user.

### 2.3.7 Communication

#### **Dry contact input**

Kinergier Mobile is equipped with a dry contact input for remote on/off, often IGN was connected.

#### **Dry contact output**

Kinergier Mobile is equipped with two NO/NC relay type dry contact output, the user can set specific functions through the TBB Link. Following is the default setting.

- Relay1: The relay is closed when the battery is under voltage.
- Relya2: The relay is closed when a fault or overload occurs.

#### **RS485**

Equipped with a RS485 interface.

### 3. Installation and Wiring



Keep away from fire, avoid direct sunlight and rain; do not store flammable, explosive or corrosive gases or liquids in the working environment. Don't install in a working environment with metal conductive dust.

- Please install the equipment in a location of dry, clean, cool with good ventilation.
- Operating temperature:  $-20\sim 65^{\circ}\text{C}$
- Storage temperature:  $-40\sim 70^{\circ}\text{C}$
- Cooling: Force fan
- Relative humidity in operation: 95% without condensation.

## 4. Operation

### 4.1 Check before Operation

Please check before Operation according to the following.

- Inverter is installed correctly and steady.
- Reasonable cable layout to meet customer requirements.
- Make sure the grounding is reliable.
- Make sure the ground wire is properly connected and firm and reliable.
- Double check the battery breaker is OFF.
- Make sure the cables are properly connected and firm and reliable.
- Reasonable installation space, clean and tidy environment, no construction residue.

### 4.2 Power ON Test



Make sure the battery voltage is within the permissible range before turning ON the breaker.

Please follow the following instruction step by step.

- Step 1: Turn on the circuit breaker between the battery and the inverter.
- Step 2: Press the On/Off button to turn on the inverter entering into self diagnostic.
- Step 3: Set the parameters following the setup wizard.
- Step 4: Press the On/Off button Again to turn on the inverter.
- Step 5: Observe the LED light to make sure the inverter is running normally.

(Refer to Table 2-2 LED directive function)

### 4.3 Power OFF



After the inverter is power OFF, there is still residual power and heat in the chassis, which may lead to electric shock or burn.

- Method 1: Press the On/Off button about 2secs to turn off the output of inverter. Afterwards, you can press and hold the On/Off for 5secs, after hearing consecutive beep, you can permanently shut down the inverter.
- Method 2: Press and hold the On/Off for 5secs, after hearing consecutive beep, you can permanently shut down the inverter straight away.



## 5. Configuration



Settings may only be changed by a qualified electrical engineer. Read the instructions thoroughly before implementing changes. During setting of the charger, the AC input must be removed.

### 5.1 Default Setting

Table 5-1 CM2.0L-LV/CM3.0L-LV factory settings

System	Rate AC Voltage	120VAC
	Rate AC Frequency	60Hz
Battery	Battery Type	AGM
	Battery AH	200AH
	Max Charge Current	100% of the Max charge current
	Absorption Voltage	14.4
	Float Voltage	13.5
	Undervoltage Protect Recover	13.0
	Undervoltage Warning	11.0
	Undervoltage Protect	10.5
	Deep Undervoltage Protect	9.9
AC Input	Power Assist Cur	32

### 5.2 Configuration

#### 5.2.1 TBB Interface

The TBB Interface is a RS485 to USB communication module.

Connect the inverter to the computer requires a TBB Interface, which goes between the COMMON port on the inverter, and a USB port on the computer.



Figure 5-1 TBB Interface

### 5.2.2 TBB Link

The TBB Link is a powerful tool for CM series inverter Configuration. The TBB Link can be installed on the computer, open the TBB Link and turn on the inverter, the inverter can be configured.

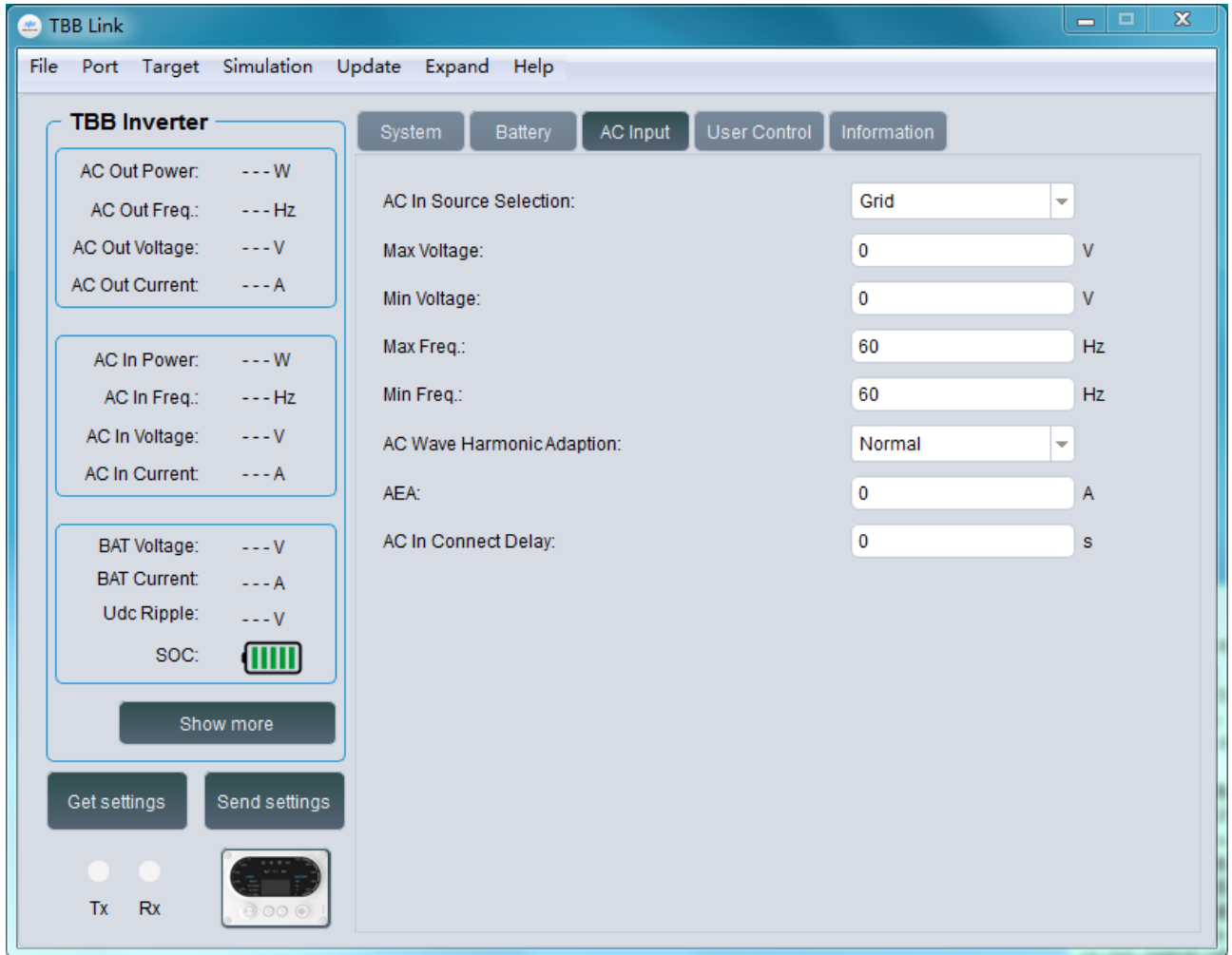



Figure 5-2 TBB-Link

## 6. Specification

Model	CM2.0L-LV	CM3.0L-LV
Power Assist	Yes	
AC inputs	Input voltage range:85~140 VAC, Input frequency:55~65Hz	
AC input Current	50A (transfer switch)	
<b>Inverter</b>		
Nominal battery voltage	12VDC	
Input voltage range	10.5~17VDC	
Output	Voltage: 110/115/120 VAC $\pm$ 2%, Frequency: 60 Hz $\pm$ 0.1%	
Harmonic distortion	<2%	
Power factor	1.0	
Cont. output power at 25°C	1600W	2400W
Output power (90min) at 25°C	2000W	3000W
Peak power	4000W	6000W
Cont. output power at 40°C	1500W	2200W
Maximum efficiency	93%	
Zero load power	12W	16W
<b>Charger</b>		
Charge voltage 'absorption'	14.4VDC	
Charge voltage 'float'	13.8VDC	
Battery types	AGM / GEL / OPZV / Lead-Carbon / Li-ion / Flooded	
Battery Charge current	100A	150A
Temperature compensation	Yes	
<b>General data</b>		
AC Out Current	50A	
Transfer time	<2ms (<15ms when Weak Grid Mode)	
Remote on-off	Yes	
Programmable relay	2x	
Protection	a) output short circuit, b) overload, c) battery voltage over voltage d) battery voltage under voltage, e) over temperature, f) Fan block g) input voltage out of range, h) input voltage ripple too high	
General purpose com. Port	RS485	
Operating temperature range	-20 to +65°C	
Storage temperature range	-40 to +70°C	
Relative humidity in operation	95% without condensation	
Altitude	2000m	
<b>Mechanical Data</b>		
Dimension	510*245*135mm	
Net Weight	15kg	20kg
Cooling	Forced fan	
Protection index	IP20	
<b>Standards</b>		
Safety	UL458 & CSA107.1	
EMC	FCC Part 15 Class B	

## **TBB POWER CO.,LTD**

 [service@tbbpower.com](mailto:service@tbbpower.com)

 [www.tbbpower.com](http://www.tbbpower.com)

 +86-592-5212299

 +86-592-5796070